

# Instant™

## VORTEX™ PLUS

10 Quart Air Fryer Oven



### User Manual

- Welcome
- Important Safeguards
- Initial Setup
- Product Overview
- Control Panel
- Initial Test Run
- Smart Programs
- Rotisserie
- Cooking Timetable
- Care & Cleaning
- Troubleshooting
- Warranty
- Support & Contact Information

# Welcome to the world of Instant cooking.

---

Hello! Thank you for welcoming us into your kitchen.

Having families ourselves, we developed the Instant™ Vortex™ Air Fryer Oven to allow busy families and professionals alike to cook healthy, delicious meals more easily and in less time.

We have partnered with chefs, authors and bloggers to compile a collection of recipes that we hope you enjoy!



Robert J. Wang  
Founder & Chief Innovation Officer

Download the FREE Instant Pot App

- Original Recipes
- New User Tips
- Getting Started Videos



Find dozens of easy to follow recipes at <https://recipes.instantpot.com/> or download the Instant Pot app at <https://instantpot.com/instant-pot-recipe-app-free-recipes/>

# IMPORTANT SAFEGUARDS

When using, to avoid the risk of serious injury when using your appliance, basic safety precautions should be followed, including the following:

1. READ ALL INSTRUCTIONS, SAFEGUARDS, AND WARNINGS BEFORE OPERATING THE APPLIANCE.
2. Always operate the appliance on a stable, non-combustible, level surface.
3. The appliance's outer surfaces may become hot during use. Do not touch hot surfaces. Wear Instant Pot® mini mitts or oven mitts when opening the oven door and handling hot components. Extreme caution must be used when moving the appliance. Let the appliance cool to room temperature before handling or moving.
4.  To protect against the risk of electrical shock, do not immerse power cord, plug, or the appliance in water or other liquid.
5. Do not rinse the appliance under tap.
6. The cooking chamber contains electrical components. To avoid electrical shock, do not put liquid of any kind into the cooking chamber.
7. This appliance is NOT to be used by children or by persons with reduced physical, sensory, or mental capabilities. Close supervision is necessary when this appliance is used near children and these individuals. Children should not use or play with this appliance.
8. Unplug from the outlet when not in use, as well as before adding or removing parts or accessories, and before cleaning. To unplug, grasp the plug and pull from the outlet. Never pull from the power cord.
9. Avoid contact with moving parts.
10. Regularly inspect the appliance and power cord. Do not operate any appliance with a damaged cord or plug or after the appliance malfunctions, or is dropped or damaged in any manner. Contact Customer Care at [support@instantappliances.com](mailto:support@instantappliances.com) or **1-800-828-7280**.
11. Do not use any accessories or attachments not authorized by Instant Brands™ Inc. The use of attachments not recommended by the manufacturer, such as fry baskets, may cause a risk of injury, fire or electric shock.
12. For household countertop use only. Do not use outdoors. Not for commercial use.



Read this manual carefully and completely, and retain for future reference. Failure to adhere to safety instructions may result in serious injury.

# IMPORTANT SAFEGUARDS

13. Do not place the appliance on any kind of stovetop, or in a heated oven; heat from an external source will damage the appliance.
14. Do not let power cord contact hot surfaces or open flame, including a stovetop.
15. Do not use appliance for anything other than intended use.
16. Proper maintenance is recommended after each use. Refer to "Care & Cleaning". Let the appliance cool to room temperature before cleaning or storage.
17.  Spilled food can cause serious burns. A short power-supply cord is provided to reduce the hazards resulting from grabbing, entanglement and tripping. Keep appliance and cord away from children. Never drape cord over edge of table or counter, never use power outlet below counter, and never use with an extension cord.
18. Do not attempt to repair, replace, alter, or modify components of the appliance. This may cause electric shock, fire and/or injury, and will void the warranty.
19. Do not tamper with any of the safety mechanisms.
20. Do not use the appliance in electrical systems other than 120V~60Hz for Canada and the USA. Do not use with power converters or adapters.
21. Do not overfill the air fryer basket. Overfilling may cause food to contact the heating element, which may result in fire and/or personal injury.
22. Do not cover the air vents while the appliance is in operation. Doing so will prevent even cooking and may cause damage to the appliance.
23. Never pour oil into the cooking chamber. Fire and personal injury could result.
24. While cooking, the internal temperature of the appliance reaches several hundred degrees. To avoid personal injury, never place unprotected hands inside the appliance until it has cooled to room temperature.
25. When cooking, do not place the appliance against a wall or against other appliances. Leave at least 5" of free space on the back, sides, and above the appliance. Do not operate the appliance on or near combustible materials such as tablecloths and curtains. Do not place anything on top of the appliance.



Read this manual carefully and completely, and retain for future reference. Failure to adhere to safety instructions may result in serious injury.

# IMPORTANT SAFEGUARDS

26. When in operation, hot air is released through the air vents. Keep your hands and face at a safe distance from the air vents and take extreme caution when removing the accessories from the appliance.
27. Should the unit emit black smoke, press **Cancel** and unplug the appliance immediately. Wait for smoking to stop before opening the door, then clean the appliance thoroughly.
28. Do not leave the appliance unattended while in use.
29. Never connect this appliance to an external timer switch or separate remote-control system.
30. Use extreme caution when removing hot accessories from the cooking chamber or disposing of hot grease.
31. Oversized foods and/or metal utensils must not be inserted into the cooking chamber as they may cause risk of fire and/or personal injury.
32. Do not store any materials, other than the included accessories, in the cooking chamber when not in use.
33. Do not place any combustible materials in the cooking chamber, such as paper, cardboard, plastic, Styrofoam or wood.
34. The included accessories are not to be used in a microwave, toaster oven, convection or conventional oven, nor on a ceramic, electric, induction or gas cooktop, or an outdoor grill.

## SAVE THESE INSTRUCTIONS



Read this manual carefully and completely, and retain for future reference.  
Failure to adhere to safety instructions may result in serious injury.

# IMPORTANT SAFEGUARDS

## WARNING

To avoid injury, read and understand instruction manual before using this machine.

## WARNING

Electrical shock hazard. Use grounded outlet only. DO NOT remove ground. DO NOT use an adapter. DO NOT use an extension cord. Failure to follow instructions can cause electrical shock and/or death.

## NOTICE

THE FAILURE TO FOLLOW ANY OF THE IMPORTANT SAFEGUARDS AND THE IMPORTANT INSTRUCTIONS FOR SAFE USE IS A MISUSE OF YOUR APPLIANCE THAT CAN VOID YOUR WARRANTY AND CREATE THE RISK OF SERIOUS INJURY.

## Special Cord Set Instructions

As per UL safety requirements, a short power supply cord (0.6 m to 0.9 m / 24 in - 35 in) is provided to reduce the hazards resulting from grabbing, entanglement and tripping

This appliance has a 3-prong grounding plug. To reduce the risk of electric shock, plug the power cord into a grounded (earthed) electrical outlet that is easily accessible.

## Product Specifications



Vortex Plus 10



10 Quart



1500W



120V~60 Hz



16.94 lb  
7.7 kg



in: 13.23L x 13.23W x 14.37H  
cm: 33.6L x 33.6W x 36.5H

## WARNING

Read this manual carefully and completely, and retain for future reference. Failure to adhere to safety instructions may result in serious injury.

# Initial Setup

---

- Remove all packaging material from, in and around the oven, as well as all accessories from inside the oven chamber.
- Follow Care & Cleaning instructions in this manual to clean the oven before first use.
- Place the oven on a stable, level surface, away from combustible material and external heat sources. Leave at least 5" of space around the oven.
- Do not place the oven on a stovetop.
- Do not place anything on top of the oven.
- Do not block the air vents.
- Read the Important Safeguards in this User Manual before using the oven. Failure to read and follow Important Safeguards may result in damage to the oven, damage to property or personal injury.

# Product Overview

---

The Vortex Plus Air Fryer Oven uses rapid air circulation to cook food, giving your meals all the crispy rich flavor of deep frying with little or no oil.

## Air Fryer Oven

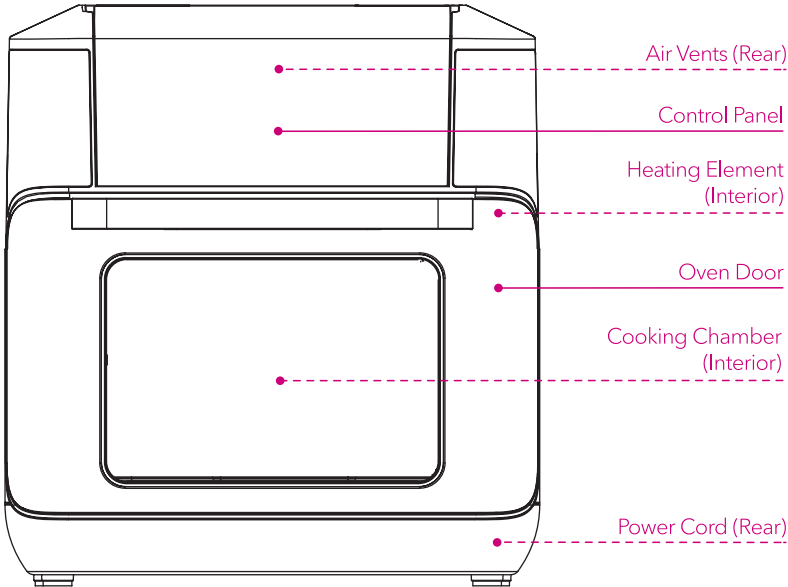

*Images are for reference only. Refer to actual product.*



# Product Overview

---

## Air Fryer Oven Accessories

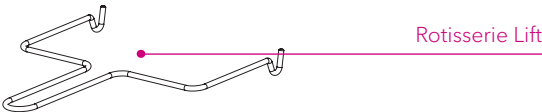
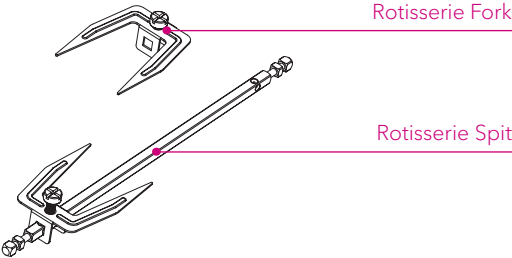
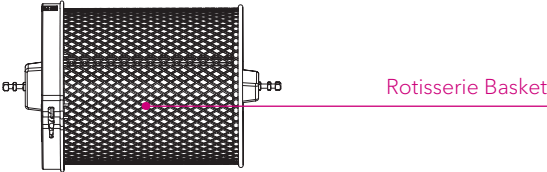
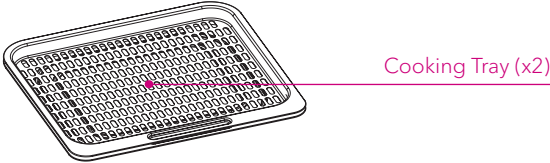
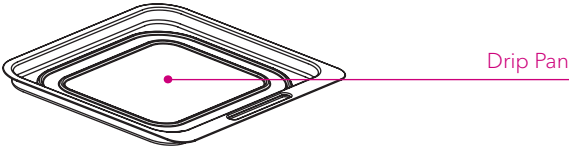

Images are for reference only. Refer to actual product.

# Control Panel

The Vortex Plus Air Fryer Oven Control Panel features intuitive touch screen controls and an LED Display.

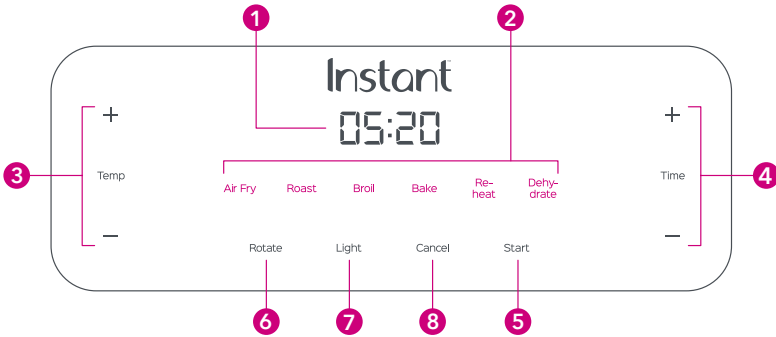

## 1 Display

Shows cooking time, cooking temperature, reminders and error messages.

## 2 Smart Programs

Smart Programs control cooking times and temperatures automatically. Select a Smart Program by touching the label on the Control Panel. Display reads "Off" to indicate that the Smart Program has been initiated and the oven is in Standby mode.

### Vortex Plus 10 Smart Programs:

- Air Fry
- Roast
- Broil
- Bake
- Reheat
- Dehydrate

**Note:** Each Smart Program includes a default cooking time and temperature.

## 3 Adjust Temperature

Touch the Temp [+] or [-] signs to adjust the cooking temperature. Touch and hold to adjust quickly.

## 4 Adjust Time

Touch the Time [+] or [-] signs to adjust the cooking time. Touch and hold to adjust quickly.

**Note:** The Smart Program saves your time and temperature adjustments when you touch Start.

## 5 Start

Touch the Start key to begin cooking.

## 6 Rotate

Once cooking has begun, touch the Rotate key to turn rotisserie rotation on and off.

**Note:** Applicable to Air Fry & Roast only. The key turns blue when the Rotate function is available.

## 7 Light

Touch the Light key to turn the oven light on or off. The oven light turns off automatically after 5 minutes.

## 8 Cancel

Touch the Cancel key to stop cooking. The oven goes into Standby mode and the Display reads "OFF".

# More Controls

---

**Smart Program Reset** When in Standby, touch and hold the Smart Program you wish to reset for 3 seconds. The Smart Program cooking time and temperature is restored to the default setting.

**Full Reset** When in Standby, touch and hold both the **Temp** and **Time** plus [+] signs at the same time for 3 seconds. All Smart Programs cooking times and temperatures are restored to the default settings.

**Sound On/Off** When in Standby (Display reads "Off"), touch and hold both the Temp and Time minus [-] signs for 3 seconds to toggle sound on or off.

**Note:** *Error alerts cannot be silenced.*

# Display Messages

**OFF** indicates that the Air Fryer is in Standby mode.



**On** indicates that the Air Fryer is in Preheating mode.



**Add food** indicates that the oven has reached desired temperature and food can be added



**00:00** indicates that the Smart Program is running. The time indicator will count down while your food is cooking.

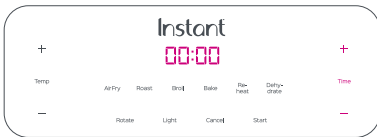

**turn Food** is a reminder to turn, flip or shake food items as recommended by your recipe.

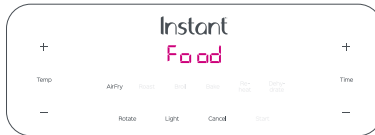

**End** indicates that the Smart Program has ended.



## Test Run

---

Follow these steps to ensure your oven is operating properly.

1. Open the oven door.  
Place the drip pan on the bottom of the cooking chamber.  
Close door.
2. Plug the power cord into a 120V power source.  
Display reads "OFF" indicating that oven is in Standby mode.
3. Touch the **Air Fry** Smart Program control on the Control Panel.  
*Note: The default Air Fry Smart Program cooking temperature is 400°F.*
4. Touch the **[+]** or **[-]** **Time** controls to adjust the cooking time to 20 minutes.  
*Note: Smart Programs automatically save your last temperature and time settings.*
5. Touch **Start** to begin cooking.  
The display reads "On" while the oven is in Preheat mode.  
Use the **Temp** **[+]** or **[-]** and **Time** **[+]** or **[-]** controls to adjust the cooking temperature or time.
6. When the oven reaches the Smart Program cooking temperature, the display reads "Add Food".  
For this test run, do not add food to the cooking chamber.
7. Open oven door.  
Use Instant Pot® mini-mitts or oven mitts and carefully insert both cooking trays into the heated cooking chamber.  
Close door.  
The cooking time and temperature will be displayed
8. Part way through the Smart Program cooking time, the oven beeps and displays "turn Food" to remind you to turn your food.  
Open the door to automatically pause the Smart Program, then close the door to resume.  
*Note: The "turn Food" reminder only appears when using Air Fry or Roast Smart Programs and only if Rotate is not turned on.*  
*Note: Cooking will recommence after 10 seconds whether food has been turned or not.*

## Test Run

---

9. Display will count down the last minute of cooking time in seconds. When the Smart Program is complete, display reads "End" and the fan blows to cool the oven.

*Note: The Air Fryer Oven will remind you that food is ready 5, 30 and 60 minutes after the Smart Program ends.*

**⚠ CAUTION**

The oven will be hot during and after cooking. Do not touch hot surfaces. Always use Instant Pot® Mini Mitts or oven mitts to remove cooking trays. Allow the oven to cool to room temperature, then clean the accessories and cooking chamber. Refer to "Care & Cleaning" in the included Safety, Maintenance & Warranty booklet.

# Smart Program Settings

Default Vortex Plus 10 Smart Program Time and Temperature settings are as shown in the table below.

Smart Program	Default Cooking Time	Available Time Range	Default Cooking Temperature	Available Temperature Range*
Air Fry	18 minutes	1 - 60 minutes	400°F / 205°C	180 - 400°F / 82 - 205°C
	For all your favorite deep-fried meals, including fries, cauliflower wings, chicken nuggets and more.			
Roast	40 minutes	1 - 60 minutes	380°F / 193°C	180 - 400°F / 82 - 205°C
	Ideal for beef, lamb, pork, poultry, vegetable dishes and more.			
Broil	8 minutes	1 - 20 minutes	400°F / 205°C	400°F / 205°C
	Direct top-down heating. Perfect for melting cheese on French onion soup, nachos and more.			
Bake	30 minutes	1 - 60 minutes	365°F / 185°C	180 - 400°F / 82 - 205°C
	Light and fluffy cakes and pastries, scalloped potatoes and more.			
Reheat	10 minutes	1 - 60 minutes	280°F / 138°C	120 - 360°F / 49 - 182°C
	Reheat leftovers without overcooking or drying out.			
Dehydrate	7 hours	1 - 15 hours	120°F / 49°C	105 - 160°F / 41 - 71°C
	Perfect for homemade fruit leather, jerky, dried vegetables and more.			

# Using the Rotisserie Accessory

Always insert rotisserie accessories and food before preheating the oven.

## To use the Rotisserie Basket

- 1 Place food items in the rotisserie basket.

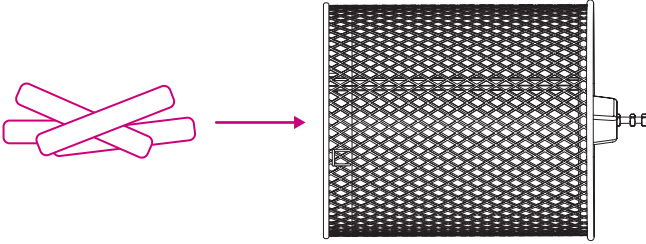

- 2 Align the tab on the rotisserie basket with the notch in the lid then place the lid.

- 3 Turn the lid clockwise to secure it.

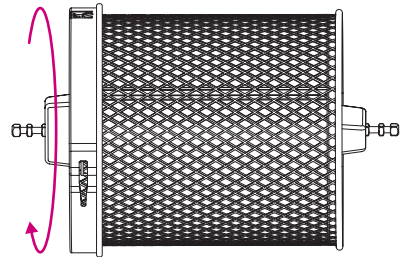
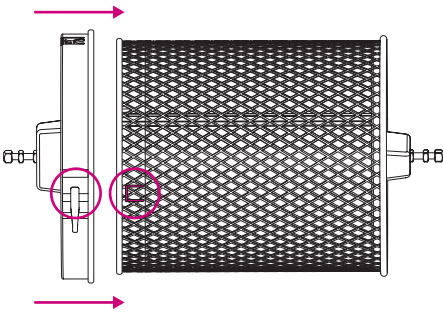

**CAUTION** Do not overfill the rotisserie basket.



# Using the Rotisserie Accessory

Always insert rotisserie accessories and food before preheating the oven.

## To use the Rotisserie Spit & Forks

- 1 Unscrew the 2 set screws.

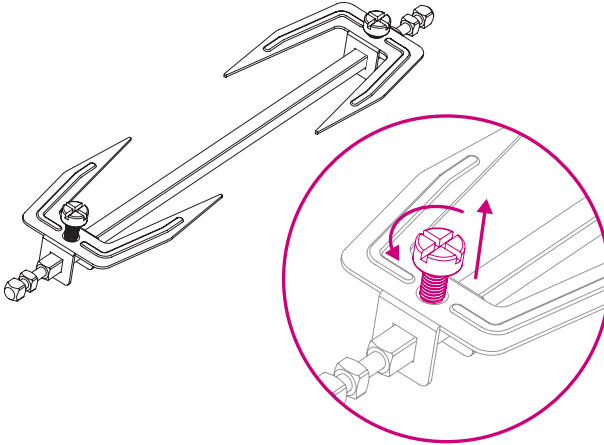

- 2 Remove the forks from the spit.

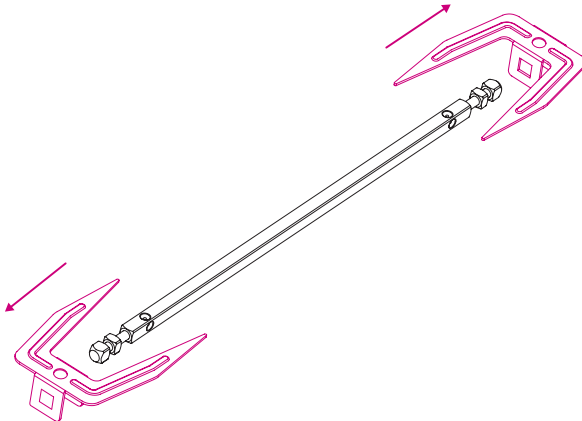

**CAUTION**

Ensure the food item is able to rotate freely. Do not allow food items to make contact with the heating coil.

# Using the Rotisserie Accessory

3 Push the food item onto the spit.

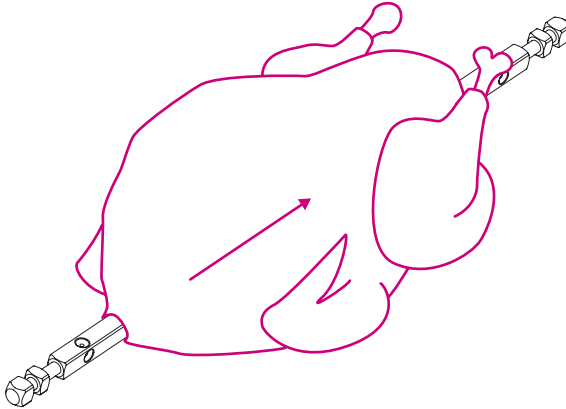

4 Slide the forks onto both ends of the spit, ensuring the prongs are inserted into the food item.

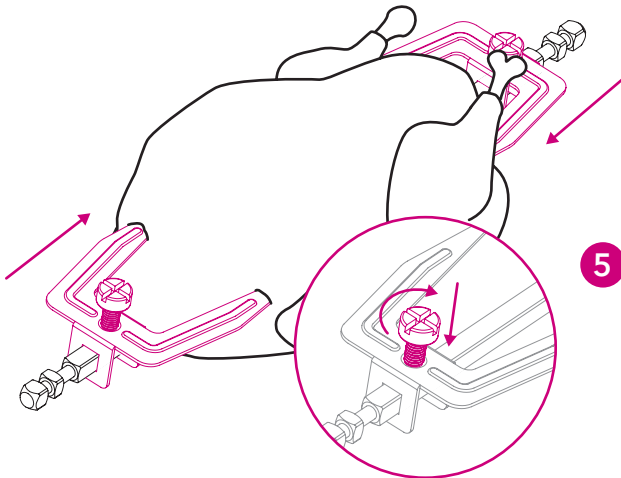

5 Tighten the set screw to secure the forks.

**CAUTION**

Ensure the food item is able to rotate freely. Do not allow food items to make contact with the heating coil.

# Using the Rotisserie Accessory

Always insert rotisserie accessories and food before preheating the oven.

## Rotisserie Cooking

- 1 With the oven door open, slide the basket accessory or rotisserie spit into the guides into the cooking chamber. Both the basket and rotisserie spit install and remove the same way.

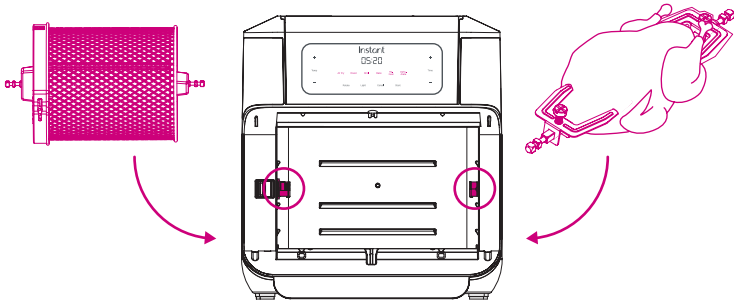

- 2 Move the rotisserie catch lever to the right and hold it in position.

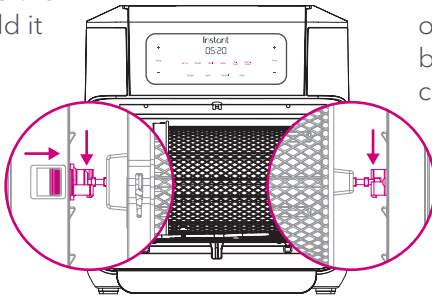

- 3 Align the rotisserie arm with the hole in the center of the rotisserie catch on both sides of the cooking chamber.

- 4 Release the rotisserie catch lever and rotate the rotisserie basket into place to ensure that the arm is held securely in place.

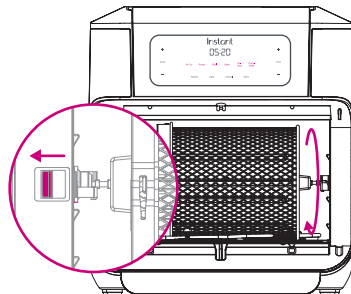

# Using the Rotisserie Accessory

5 Close the oven door.

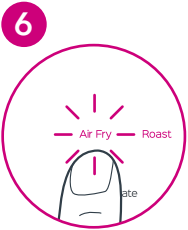
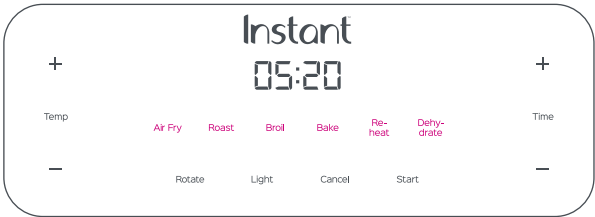
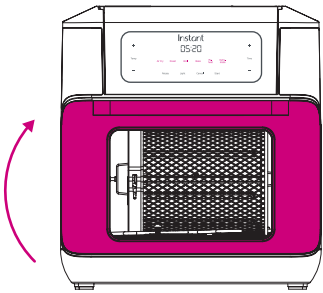

Select **Air Fry** or **Roast**.

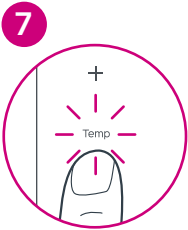

Use the **Temp** and **Time** [+ / -] controls to adjust cooking temperature and time as desired.

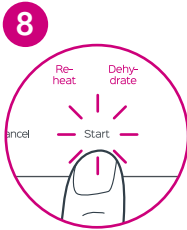

Touch **Start**.

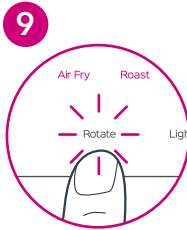

Touch **Rotate**.

# Using the Rotisserie Accessory

## Removing the Accessory

- 1 Use caution when opening oven door. Door and accessories will be hot. Position the rotisserie lift hooks beneath the left and right arms of the accessory.

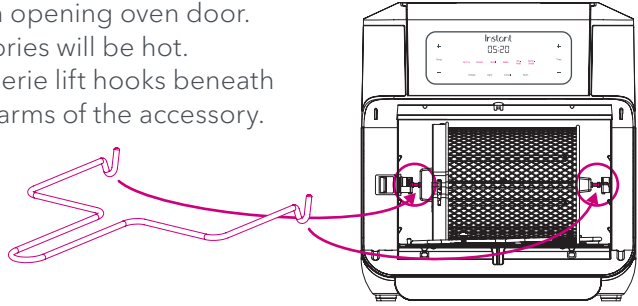

- 2 Move the rotisserie catch lever to the right to release the accessory.

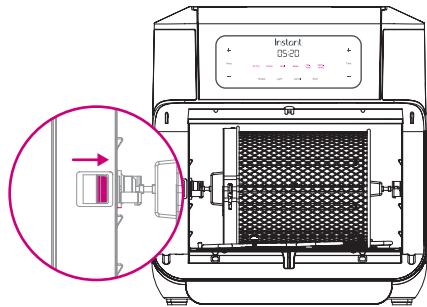

- 3 Pull the accessory towards you, then release the rotisserie catch lever.

- 4 Carefully remove the accessory from the cooking chamber.

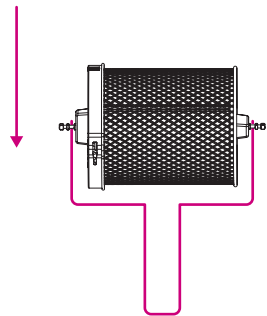

### **⚠️ WARNING**

Rotisserie spit, forks, and basket will be hot during and after cooking. Always use the rotisserie lift to remove rotisserie accessories, and exercise extreme caution when removing hot accessories from the cooking chamber. Always use Instant Pot® Mini Mitts or oven mitts when disassembling hot rotisserie accessories.

# Cooking Timetable

Food	Setting	Cooking Time*	Cooking Temperature*	Accessory & Placement
Thin-cut fries (Frozen)	Air Fry / Roast	14 - 18 minutes	400°F / 205°C	Rotisserie Basket
Thin-cut fries (Fresh)	Air Fry / Roast	18 - 20 minutes	400°F / 205°C	Rotisserie Basket
Thick-cut fries (Frozen)	Air Fry / Roast	16 - 20 minutes	400°F / 205°C	Rotisserie Basket
Thick-cut fries (Fresh)	Air Fry / Roast	20 - 25 minutes	400°F / 205°C	Rotisserie Basket
Chicken wings	Air Fry / Roast	20 - 30 minutes	360°F / 182°C	Cooking Tray, Bottom / Rotisserie Basket
Whole chicken (up to 4 lbs)	Roast	50 - 70 minutes	380°F / 193°C	Rotisserie Spit
Chicken nuggets (Frozen)	Broil	10 - 15 minutes	400°F / 205°C	Cooking Tray, Middle / Rotisserie Basket
Shrimp (Frozen)	Air Fry	8 minutes	400°F / 205°C	Cooking Tray, Middle / Rotisserie Basket
Shrimp (Fresh)	Air Fry	8 - 10 minutes	350°F / 177°C	Cooking Tray, Middle / Rotisserie Basket
Fish sticks (Frozen)	Broil	8 - 12 minutes	400°F / 205°C	Cooking Tray, Middle
Asparagus	Broil / Bake	7 - 9 minutes	370°F / 188°C	Cooking Tray, Middle / Rotisserie Basket
Cauliflower	Broil / Bake	6 - 10 minutes	370°F / 188°C	Cooking Tray, Middle / Rotisserie Basket
Cake	Bake	25 - 35 minutes	360°F / 182°C	Drip Pan, Bottom (Springform Pan)

*\*Note: Cooking times and temperatures are recommendations only. Always follow a trusted recipe.*

**CAUTION** Always use a meat thermometer to ensure the internal temperature of poultry reaches at least 165°F / 75°C.

## Cooking Tips

---

Instant Air Fryer Ovens can cook all your favorite fresh and frozen oven-baked, and deep-fried snacks—fast!

- Use the Smart Programs as a starting point and experiment with cooking times, and temperatures to get the results your prefer.
- Rotisserie-cooked foods and rotisserie accessories, and foods must be placed in the oven before touching **Start**
- With the exception of rotisserie-cooked foods, most foods will benefit greatly from a preheated oven. Wait for the display to read **"Add Food"** before inserting food into the cooking chamber.
- When cooking coated food items, choose breadcrumb batters over liquid-based batters to ensure that the batter will stick to the food.
- Flip or rotate food items when the display indicates **"turn Food"** to ensure they are evenly cooked on both sides.
- For crispy, golden fries, soak fresh potato sticks in ice water for 15 minutes, pat dry and spray lightly with cooking oil before inserting them to the oven.
- When baking cake, pie, quiche, or any food with filling or batter, use an oven-safe baking dish and cover food with foil or an oven-safe lid to prevent the top from overcooking.
- The drip pan doubles as a flat cooking tray. Use the drip pan when cooking fragile or filled foods.
- When cooking pizza, insert both cooking trays into the oven and place the pizza on the bottom cooking tray.
- Pat moist food items dry before cooking to prevent steam, splatter and excess steam.
- Air frying can cause oil and fat to drip from foods. To prevent excess smoke, carefully remove and empty the drip pan periodically throughout cooking.
- To ensure seasoning adheres to food items, spray food items with cooking oil before adding seasoning.
- Feel free to use any oven-safe cookware in your Air Fryer Oven.

## Cooking Tips

---

- Find dozens of easy to follow recipes at:  
[recipes.instantpot.com](https://recipes.instantpot.com)

Download the Instant Pot app at:

[instantpot.com/instant-pot-recipe-app-free-recipes/](https://instantpot.com/instant-pot-recipe-app-free-recipes/)



### **CAUTION**

Do not spray cooking oil into the cooking chamber.



## Care & Cleaning

Always unplug your Vortex Plus Air Fryer Oven and let it cool to room temperature before cleaning.

Never use harsh chemical detergents, scouring pads, or powders on any of the parts or components.

Part / Accessory	Instruction	Cleaning Method
Rotisserie Basket	Clean after each use. For best results, use a bristled brush rather than a sponge or cloth. Optionally, spray with non-stick cooking spray before adding food.	Dishwasher or Hand Wash
Rotisserie Spit & Forks	Disassemble and clean after each use.	
Cooking Trays	Do not cover cooking trays when cooking. Air must be able to circulate freely. Clean after each use. Cooking trays have a non-stick coating. Do not use metal utensils when cleaning.	
Rotisserie Lift	Clean as needed.	
Drip Pan	Remove and clean after each use. Ensure that all grease and food debris removed. Optionally, line the pan with aluminum foil or parchment paper for easier cleaning.	
Cooking Chamber	Clean the cooking chamber walls as needed. Always check the heating coil for food debris and clean the heating coil as needed. Ensure the heating coil is dry before next use.	Damp Cloth Only
Removable Door	Allow to air-dry completely before reinstalling.	
Outer Body & Stainless Steel	Clean with a soft, damp cloth or sponge, and wipe dry to prevent streaking.	

**Note:** To remove baked-on grease and food residue from accessories, and the cooking chamber, spray with a mixture of baking soda and vinegar and wipe clean with damp cloth. For stubborn stains, allow the mixture to sit on the affected area for several minutes before scrubbing clean.

# Care & Cleaning

---

## Remove the Oven Door

1. Place one hand on top of the Air Fryer Oven to hold it firmly in place.
2. Open the door to a 45° angle from the oven.
3. Pull the door up from the right side until it pops out of its track

## Reinstall the Oven Door

1. Hold the door at a 45° angle from the oven
2. Align the teeth at the bottom of the oven door with the grooves in the Air Fryer Oven.
3. Press down on the right side of the oven door until it pops into place, then press the left side down.

### **WARNING**

Do not immerse the appliance in water. Do not rinse the appliance under a tap. Do not wet prongs of power cord.

Without proper cleaning, food and grease splatter may build up around the heating element, causing the risk of smoke, fire, and personal injury.

If you smell smoke, touch **Cancel** and unplug the appliance. Once cool, remove food splatter or grease with a soft cloth and mild detergent.

# Troubleshooting

Register your product today at [instantappliances.com/support/register](https://instantappliances.com/support/register).

Problem	Possible Reason	Try This
Black smoke coming from Air Fryer	Using an oil with a low smoke point	<b>Cancel</b> the Smart Program, unplug the oven and allow it to cool to room temperature. Choose a neutral oil with a high smoke point, such as Virgin or Extra Virgin Olive Oil, Avocado, Canola, Soybean, Safflower, or Rice Bran.
	Food residue on the bottom of the cooking chamber, or accessories	<b>Cancel</b> the Smart Program, unplug the oven and allow it to cool to room temperature. Remove all accessories from the cooking chamber and clean the area as well as all accessories thoroughly.
	Faulty circuit or heating element	<b>Cancel</b> the Smart Program, unplug the oven and allow it to cool. Contact Customer Care Team. <b>Note:</b> Do not attempt to repair the appliance.
White smoke coming from Air Fryer	Cooking foods with high fat content, such as bacon, sausage, and hamburger	Avoid air frying foods with a high fat content. Check drip pan/crumb tray for excess oil or fat and carefully remove as needed after cooking.
	Water is vaporizing producing thick steam	Pat dry moist food ingredients before air frying. Do not add water or other liquid to cooking chamber when air frying.
	Seasoning on food has blown into element	Be mindful when seasoning food. Spray vegetables and meats before adding seasoning so they adhere to the ingredients.
Air Fryer is plugged in but will not turn on	The appliance is not properly plugged in	Ensure the power cord is plugged into the outlet firmly.
	Outlet is not powered	Plug in another appliance to the same plug to test the circuit.
		Move the Air Fryer to another plug.
Door is open	Ensure the oven door is closed.	
All lights flash and a code appears on the display	E1 Broken circuit of the thermal sensor	Contact Customer Care Team.
	E2 Short circuit of the thermal sensor	Contact Customer Care Team.

If the problems persist or for any service issue, contact an authorized service representative at [support@instantappliances.com](mailto:support@instantappliances.com) or by creating a support ticket [instantappliances.com/support](https://instantappliances.com/support).

# Warranty

---

## Limited Warranty

This Limited Warranty is effective for one year from the date of original consumer purchase. Proof of original purchase date and, if requested by an authorized representative of Instant Brands Inc. ("Instant Brands"), return of your appliance, is required to obtain service under this Limited Warranty. Provided that this appliance is operated and maintained in accordance with written instructions attached to or furnished with the appliance, Instant Brands will, in its sole and exclusive discretion, either: (i) repair defects in materials or workmanship; or (ii) replace the appliance. In the event that your appliance is replaced, the Limited Warranty on the replacement appliance will expire 12 months from the date of original consumer purchase.

**This Limited Warranty extends only to the original purchaser and use of the appliance in the United States of America and Canada. This warranty does not cover units that are used outside of the United States of America and Canada.**

Any modification or attempted modification to your appliance may interfere with the safe operation of the appliance and will void this Limited Warranty. This Limited Warranty does not apply in respect of any appliance or any part thereof that has been altered or modified unless such alterations or modifications were expressly authorized by an Instant Brands representative.

## Limitation and Exclusions

The liability of Instant Brands, if any, for any allegedly defective appliance or part shall in no circumstances exceed the purchase price of a comparable replacement appliance.

### **This Limited Warranty does not cover:**

1. Damage resulting from accident, alteration, misuse, abuse, neglect, unreasonable use, use contrary to the operating instructions, normal wear and tear, commercial use, improper assembly, disassembly, failure to provide reasonable and necessary maintenance, fire, flood, acts of God or repair by anyone unless directed by an Instant Brands Representative;
2. Repairs where your appliance is used for other than normal, personal use or when it is used in a manner that is contrary to published user or operator instructions; or
3. Use of unauthorized parts and accessories, or repairs to parts and systems resulting from unauthorized repairs or modifications made to this appliance.

The cost of repair or replacement under these excluded circumstances shall be paid by you.

# Warranty

---

## Disclaimer of Implied Warranties

EXCEPT AS EXPRESSLY PROVIDED HEREIN AND TO THE EXTENT PERMITTED BY LAW, INSTANT BRANDS MAKES NO WARRANTIES, CONDITIONS OR REPRESENTATIONS, EXPRESS OR IMPLIED, BY STATUTE, USAGE, CUSTOM OF TRADE OR OTHERWISE WITH RESPECT TO THE APPLIANCES OR PARTS COVERED BY THIS WARRANTY, INCLUDING BUT NOT LIMITED TO, WARRANTIES, CONDITIONS, OR REPRESENTATIONS OF WORKMANSHIP, MERCHANTABILITY, MERCHANTABILITY QUALITY, FITNESS FOR A PARTICULAR PURPOSE OR DURABILITY.

Some states or provinces do not allow for the exclusion of implied warranties of merchantability or fitness, so this limitation may not apply to you. In these states and provinces, you have only the implied warranties that are expressly required to be provided in accordance with applicable law.

## Limitation of Remedies; Exclusion of Incidental and Consequential Damage

YOUR SOLE AND EXCLUSIVE REMEDY UNDER THIS LIMITED WARRANTY SHALL BE APPLIANCE REPAIR OR REPLACEMENT AS PROVIDED HEREIN. INSTANT BRANDS SHALL NOT BE LIABLE FOR INDIRECT, INCIDENTAL OR CONSEQUENTIAL DAMAGES ARISING OUT OF OR IN CONNECTION WITH THE USE OR PERFORMANCE OF THE APPLIANCE OR DAMAGES WITH RESPECT TO ANY ECONOMIC LOSS, PERSONAL INJURY, LOSS OF PROPERTY, LOSS OF REVENUES OR PROFITS, LOSS OF ENJOYMENT OR USE, COSTS OF REMOVAL, INSTALLATION OR OTHER INDIRECT, INCIDENTAL OR CONSEQUENTIAL DAMAGES OF ANY NATURE OR KIND.

## Warranty Registration

Please visit [www.instantappliances.com/support/register](http://www.instantappliances.com/support/register) to register your new Instant Brands™ appliance and validate your warranty within thirty (30) days of purchase. You will be asked to provide the store name, date of purchase, model number (found on the back of your appliance) and serial number (found on the bottom of your appliance) along with your name and email address. The registration will enable us to keep you up to date with product developments, recipes and contact you in the unlikely event of a product safety notification. By registering, you acknowledge that you have read and understand the instructions for use, and warnings set forth in the accompanying instructions.

## Warranty Service

**To obtain service under this warranty, please contact our Customer Service Department by phone at 1-800-828-7280 or by email to [support@instantappliances.com](mailto:support@instantappliances.com). You can also create a support ticket online at [www.instantappliances.com/support](http://www.instantappliances.com/support). If we are unable to resolve the problem, you may be asked to send your appliance to the Service Department for quality inspection.** Instant Brands is not responsible for shipping costs related to warranty service, save and except for shipping costs associated with the return of your appliance from Canada or within the 48 contiguous states and the District of Columbia of the United States of America, as provided herein. When returning your appliance, please include your name, mailing address, email address, phone number, and proof of the original purchase date as well as a description of the problem you are encountering with the appliance.

# Instant™

Instant Brands Inc.  
11 - 300 Earl Grey Dr., Suite 383  
Ottawa, Ontario  
K2T 1C1  
Canada

Register your product today at:  
[instantappliances.com/support/register](https://instantappliances.com/support/register)

Contact Customer Care:  
[1-800-828-7280](tel:1-800-828-7280)  
[support@instantappliances.com](mailto:support@instantappliances.com)  
[instantappliances.com/#Chat](https://instantappliances.com/#Chat)

[instantappliances.com](https://instantappliances.com)  
[store.instantappliances.com](https://store.instantappliances.com)